

Aluminium- Füllstabgeländer SF 120

Einfache Fertigung – Sägen und Bohren
 Problemlose Montage, da zweigeteilter Handlauf
 Hohe Sicherheit bei Unfällen
 Leichtes Auswechseln beschädigter Teile ohne Spezialwerkzeug

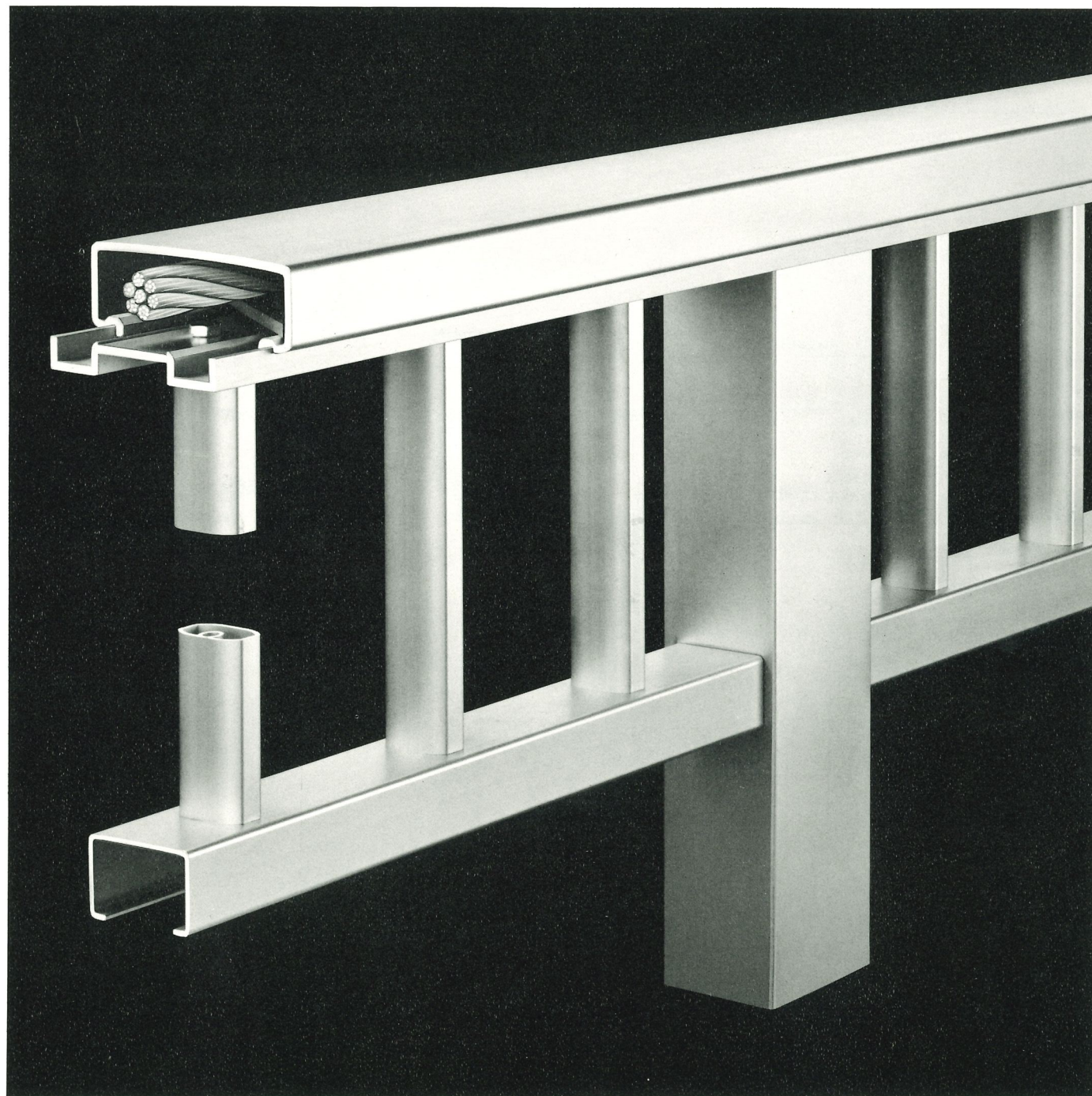

Profile und Zubehör

